



# BLUMOTION S

One solution – three technologies

[www.blum.com](http://www.blum.com)

 **blum**<sup>®</sup>

## The world is complicated enough

Requirements for individuality and a wide range of design possibilities are becoming more exacting. Therefore, it is even more important that these requirements are met in a simple way. That is why we strive for technically sophisticated product innovations, to make things easier for you.

 **blum**



## Simply better: BLUMOTION S

The flexibility to implement multiple motion technologies with only one runner, and one optimal dampening function that has been adjusted to the respective technology – this is what our new BLUMOTION S for LEGRABOX and MOVENTO offers.

**blum**

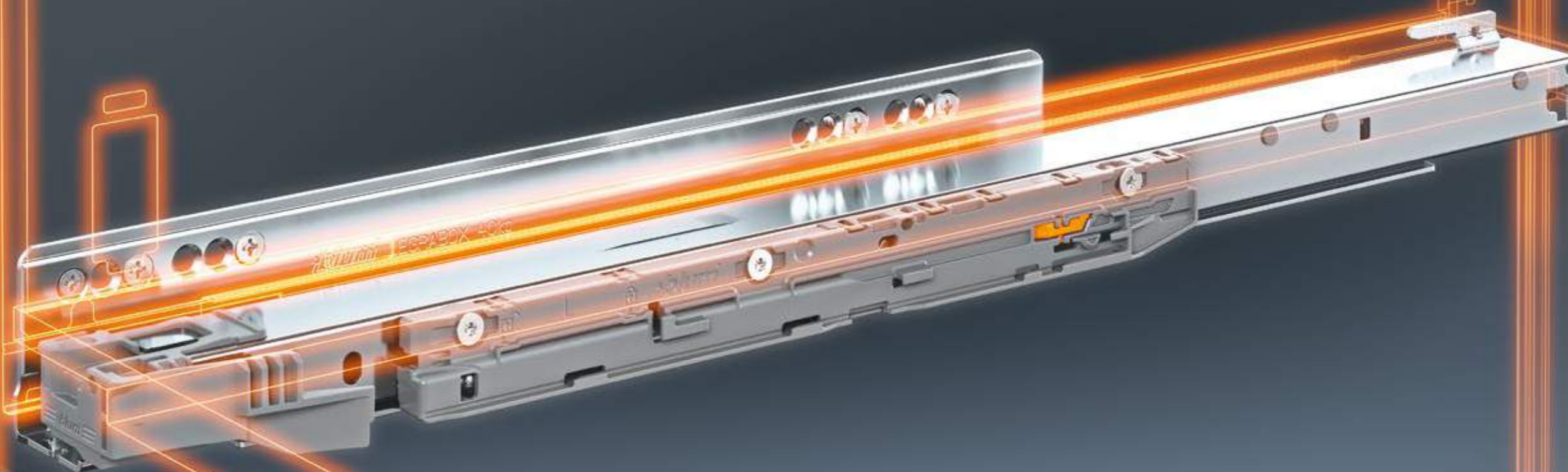

### Optimised BLUMOTION

Have you ever slammed a pull-out shut? It's great to have the BLUMOTION S runner installed in this case, isn't it? The optimised dampening path increases the dampening performance – and pull-outs can be closed even more silently.

## Simply better: BLUMOTION S

The flexibility to implement multiple motion technologies with only one runner, and one optimal dampening function that has been adjusted to the respective technology – this is what our new BLUMOTION S for LEGRABOX and MOVENTO offers.

**blum**

### TIP-ON BLUMOTION

You want drawers and pull-outs that not only close silently but can also be opened with just a light touch? TIP-ON BLUMOTION is ideally suited for this. The BLUMOTION S runner is retained, and the opening support system is added. Thanks to the unique intelligent product design the dampening path adjusts automatically. The assembly is tool-free.

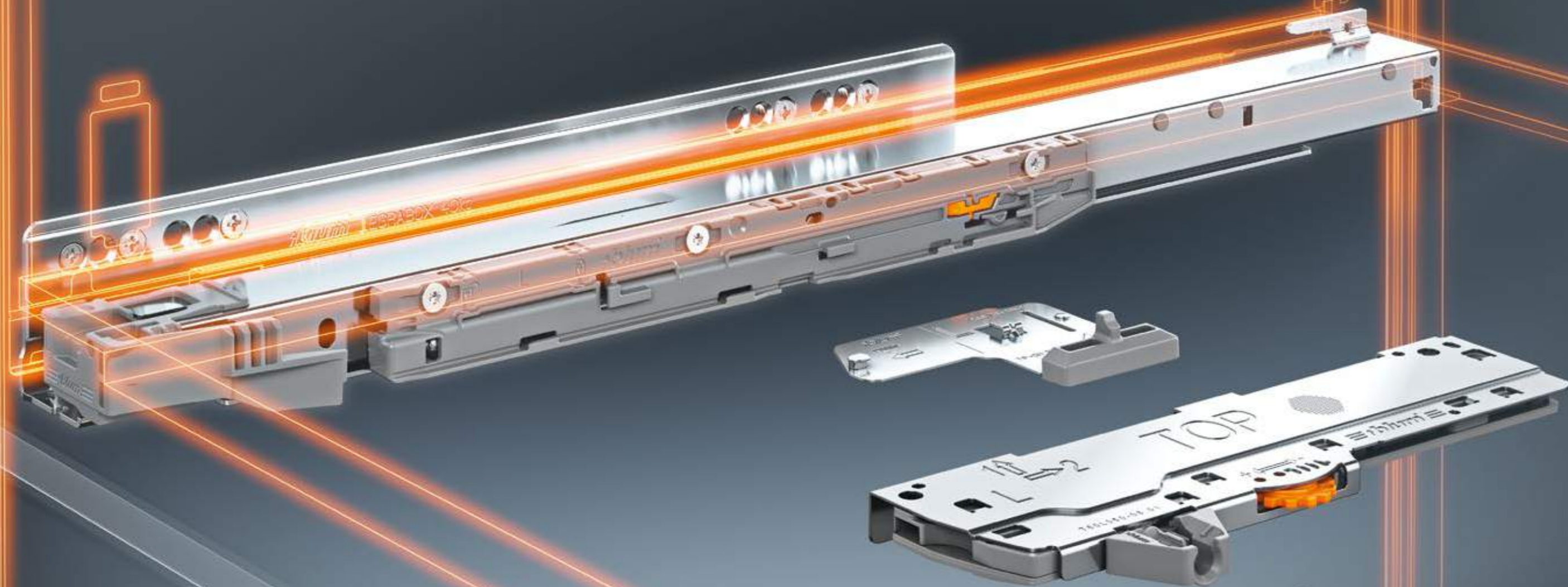

### SERVO-DRIVE

You want the highest possible usability during opening and closing? Then SERVO-DRIVE is the solution for you. The BLUMOTION S runner is supplemented here with the respective SERVO-DRIVE components.

## Simply flexible: BLUMOTION S

The BLUMOTION S runner improves on the crucial parts, while retaining the familiar straightforward assembly. The markings on the BLUMOTION S housing help with the tool-free and time-saving assembly of TIP-ON BLUMOTION components.

**blum**



### Same components

Both TIP-ON BLUMOTION and SERVO-DRIVE use the existing motion technology components. Accessories like the side stabiliser for wide drawers and pull-outs remain the same as well.



### Drilling and fixing positions remain unchanged

The drilling and fixing positions remain the same for each of the three motion technologies. This way, BLUMOTION S can offer higher flexibility while keeping the same fittings.



### Familiar adjustment options

The integrated adjustment of height, side, tilt and depth produces an attractive gap layout for LEGRABOX and MOVENTO.

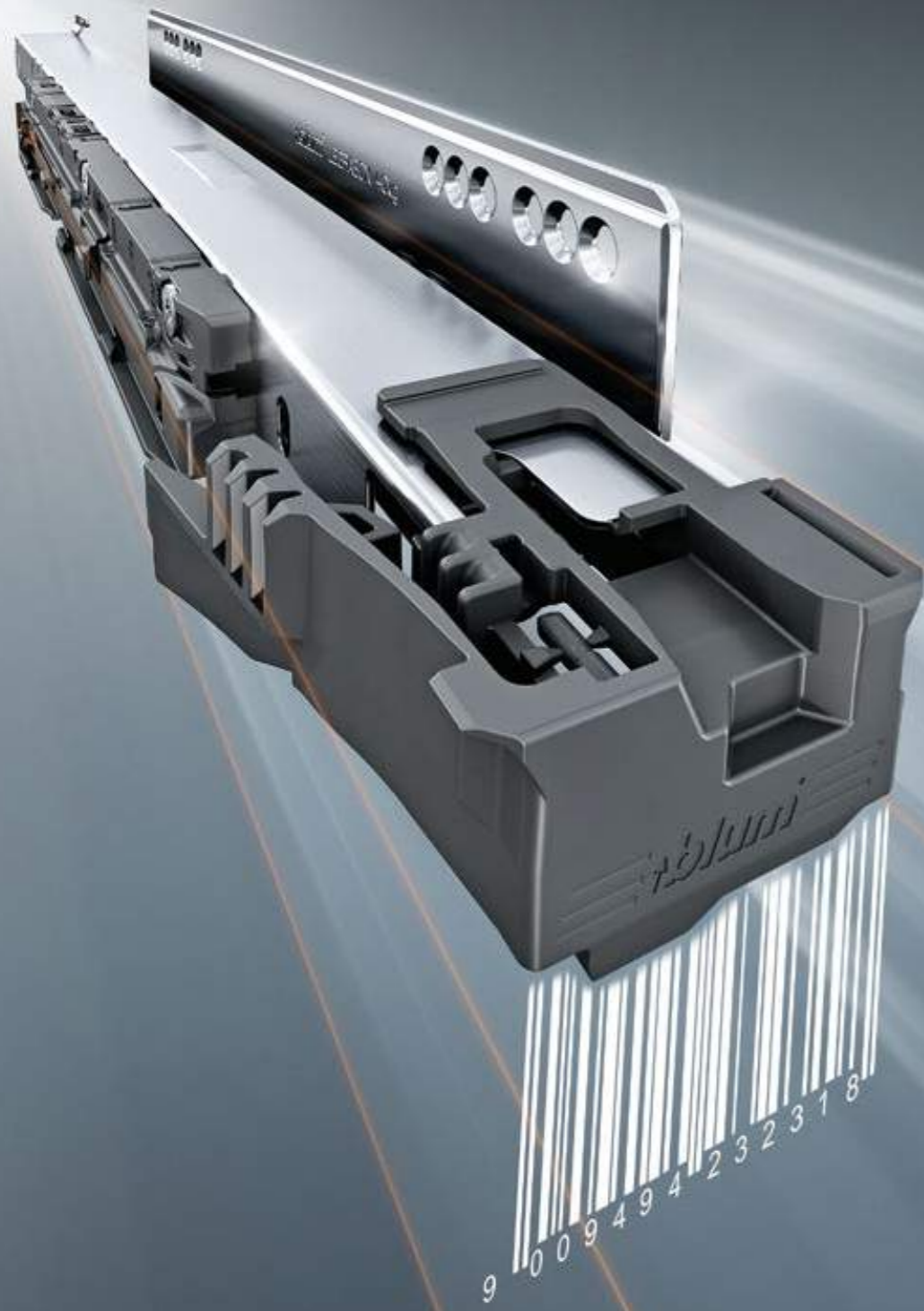

One solution – three technologies.

BLUMOTION S



BLUMOTION

S

switchable

7x0.xxxxS

- The runner can be used for three motion technologies: SERVO-DRIVE, BLUMOTION and TIP-ON BLUMOTION
- Integrated, switchable BLUMOTION S for a silent and effortless closing action
- The dampening path will be automatically adapted to the respective motion technology

LEGRABOX

Cabinet profiles left/right			
	NL	40 kg	70 kg
	270 mm	750.2701S	
	300 mm	750.3001S	
	350 mm	750.3501S	
	400 mm	750.4001S	
	450 mm	750.4501S	753.4501S
	500 mm	750.5001S	753.5001S
	550 mm	750.5501S	753.5501S
	600 mm	750.6001S	753.6001S
	650 mm		753.6501S

MOVENTO

Runners left/right			
	NL	40 kg	60 kg
	250 mm	760H2500S	
	270 mm	760H2700S	
	300 mm	760H3000S	
	320 mm	760H3200S	
	350 mm	760H3500S	
	380 mm	760H3800S	
	400 mm	760H4000S	
	420 mm	760H4200S	
	450 mm	760H4500S	766H4500S
	480 mm	760H4800S	
	500 mm	760H5000S	766H5000S
	520 mm	760H5200S	766H5200S
	550 mm	760H5500S	766H5500S
	580 mm		766H5800S
	600 mm	760H6000S	766H6000S
	650 mm		766H6500S
700 mm		766H7000S	
750 mm		766H7500S	

Left/right runners for base mounting			
	NL	40 kg	60 kg
	350 mm	760H3500SU	
	400 mm	760H4000SU	
	450 mm	760H4500SU	
	500 mm	760H5000SU	

## Optimise your inventory

Our new runner now provides you with even more.  
Fill your warehouse with possibilities not products!



NL Nominal length

# The company Blum

Founded over 60 years ago by Julius Blum, Blum is a family-owned company that operates on an international scale. Its strategic business segments include lift, hinge and pull-out systems. All our product developments focus on perfecting motion.

[www.blum.com](http://www.blum.com)



## Blum in Austria and around the world

The company has eight plants in Vorarlberg, Austria, additional production sites in Poland, the USA and Brazil and 30 subsidiaries/representative offices. Blum supplies more than 120 markets. The Blum Group employs 7.600 people in total, 5.800 of whom work in Vorarlberg.



## Global customer benefits

“Whether manufacturer, distributor, fitter or kitchen user – everybody should personally enjoy the benefits of Blum products” – that is Blum’s philosophy on global customer benefits.



## Innovations

To support customers with innovative fittings solutions and secure long-term success for the company, we need to consistently invest in research and development, in plants and facilities and in employee training. With more than 2.100 granted patents worldwide, Blum is one of Austria’s most innovative companies.



## Quality

Blum’s comprehensive concept of quality does not only apply to products. Services and collaboration with customers and partners should also meet the same quality requirements.



## Environment

At Blum, we believe that responsible ecological behaviour has long-term economic benefits. The longevity of products is just one of many important aspects. Other important measures include the use of environmentally-friendly processes, the intelligent use of materials and prudent energy management.



## DYNAMIC SPACE

Good workflows, optimum use of storage space and top quality motion are important features of a practical kitchen. Blum’s ideas for practical kitchens are designed to bring function, convenience and ergonomics to furniture interiors.

Julius Blum GmbH  
Furniture Fittings Mfg.  
6973 Höchst, Austria  
Tel.: +43 5578 705-0  
Fax: +43 5578 705-44  
E-mail: [info@blum.com](mailto:info@blum.com)  
[www.blum.com](http://www.blum.com)

